

K07 TYPE -40°C +85°C 2000H

RoHS Compliant
Directive 2002/95/EC

- Surge-proof capacitor in aluminium can with insulation sleeve
- To be mounted with ring clips or with threaded stud
- Case size optimized for Asian Market

APPLICATIONS

Industrial Market, UPS, Frequency Converters

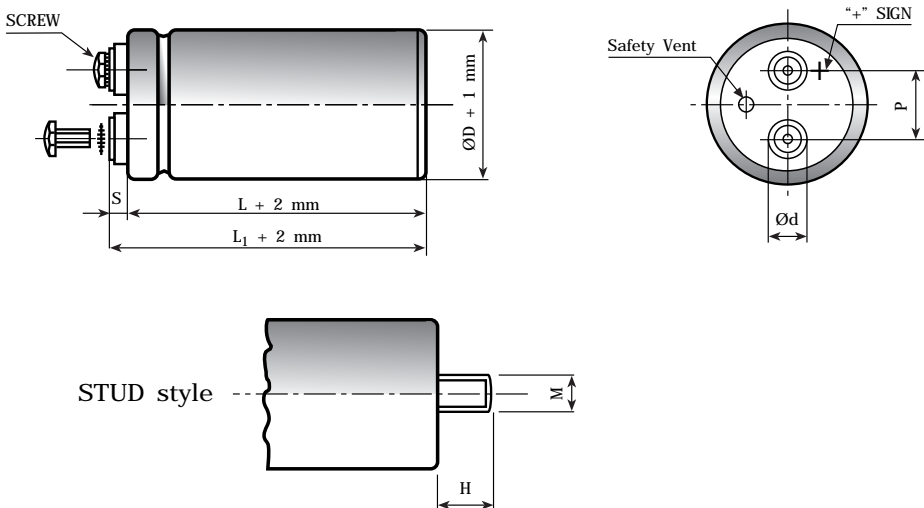

Diagram of dimensions (unit=mm)

ØD	d	P	M	H	SCREW
35	11	12.7	M 8	12	5MA x 9,5
51	18.5	22.7	M 12	16	5MA x 9,5
63	18.5	28.6	M 12	16	5MA x 9,5
76	18.5	31.8	M 12	16	5MA x 9,5
76	18.5	31.8	M 12	16	6MA x 10
90	18.5	31.8	M 12	16	6MA x 10
L ₁	L ₁ = L + 2.5 mm L ₁ toll. - 0+3 mm		L ₁ = L + 4.5 mm L ₁ toll. - 1+3 mm		
S	M5 = 5 - 0 + 1 mm From top of deck		M6 = 7 - 1 + 1 mm From top of deck		

SPECIFICATIONS

Temperature Range	Operating: -40°C +85°C Storage : Preferably below +25°C, not exceeding +40°C																									
Rated Voltage Range (V _r)	from 160V to 350V DC from 400V to 450V DC																									
Surge Voltage (V _p)	V _p = 1.15 V _r (V _r ≤ 250V DC) V _p = 1.10 V _r (V _r ≤ 250V DC)																									
Rated Capacitance Range	from 1800 μF to 47000 μF																									
Capacitance Tolerance	±20% at 120 Hz, 20°C [M class IEC-62] on request: -10% +30% at 120 Hz, 20°C [Q class IEC-62]																									
Leakage Current (I _L) (5 min, 20°C)	max I _L = 0.008 C _r V _r + 4 μA																									
Ripple current (I _r)	Refer to table at 85°C and 120Hz: <table border="1" style="width: 100%; border-collapse: collapse;"> <thead> <tr> <th style="text-align: left;">FREQUENCY</th> <th style="text-align: center;">50Hz</th> <th style="text-align: center;">100Hz</th> <th style="text-align: center;">500Hz</th> <th style="text-align: center;">1000Hz</th> <th style="text-align: center;">>10kHz</th> </tr> </thead> <tbody> <tr> <td style="text-align: left;">MULTIPLIER</td> <td style="text-align: center;">0.88</td> <td style="text-align: center;">1.0</td> <td style="text-align: center;">1.45</td> <td style="text-align: center;">1.5</td> <td style="text-align: center;">1.55</td> </tr> </tbody> </table> Due to the current load capability of the contact elements, the following limits must not be exceeded: <table border="1" style="width: 100%; border-collapse: collapse;"> <thead> <tr> <th style="text-align: left;">CAPACITOR DIAMETER</th> <th style="text-align: center;">35mm</th> <th style="text-align: center;">51mm</th> <th style="text-align: center;">63mm</th> <th style="text-align: center;">76mm</th> <th style="text-align: center;">90mm</th> </tr> </thead> <tbody> <tr> <td style="text-align: left;">Maximum current</td> <td style="text-align: center;">20A</td> <td style="text-align: center;">30A</td> <td style="text-align: center;">40A</td> <td style="text-align: center;">50A</td> <td style="text-align: center;">70A</td> </tr> </tbody> </table>		FREQUENCY	50Hz	100Hz	500Hz	1000Hz	>10kHz	MULTIPLIER	0.88	1.0	1.45	1.5	1.55	CAPACITOR DIAMETER	35mm	51mm	63mm	76mm	90mm	Maximum current	20A	30A	40A	50A	70A
FREQUENCY	50Hz	100Hz	500Hz	1000Hz	>10kHz																					
MULTIPLIER	0.88	1.0	1.45	1.5	1.55																					
CAPACITOR DIAMETER	35mm	51mm	63mm	76mm	90mm																					
Maximum current	20A	30A	40A	50A	70A																					
Insulation Resistance	At 100V DC for 1 min is >100 MΩ across insulating sleeve and terminals.																									
Vibration Resistance	Frequency range: 10 Hz to 55 Hz, amplitude 0.75 mm Capacitor length ≤ 130 : max acceleration 10G for 3x2 h Capacitor length > 130 : max acceleration 5G for 3x0.5 h																									
Life test	After 2,000 hours application of rated voltage at 85°C capacitors meet characteristics aside	<table style="width: 100%;"> <tr> <td>Cap change</td> <td style="text-align: right;">≤ ±15%</td> </tr> <tr> <td>tan δ</td> <td style="text-align: right;">≤ 175%</td> </tr> <tr> <td>Leakage current (I_L)</td> <td style="text-align: right;">< initial limit</td> </tr> <tr> <td>Impedance (Z)</td> <td style="text-align: right;">≤ 175%</td> </tr> </table>	Cap change	≤ ±15%	tan δ	≤ 175%	Leakage current (I _L)	< initial limit	Impedance (Z)	≤ 175%																
Cap change	≤ ±15%																									
tan δ	≤ 175%																									
Leakage current (I _L)	< initial limit																									
Impedance (Z)	≤ 175%																									
Shelf life	After leaving capacitors under no load for 500 hours at 85°C, when restored at 20°C meet specifications aside	<table style="width: 100%;"> <tr> <td>Cap change</td> <td style="text-align: right;">≤ ±15%</td> </tr> <tr> <td>tan δ</td> <td style="text-align: right;">≤ 150%</td> </tr> <tr> <td>Leakage current (I_L)</td> <td style="text-align: right;">< initial limit</td> </tr> </table>	Cap change	≤ ±15%	tan δ	≤ 150%	Leakage current (I _L)	< initial limit																		
Cap change	≤ ±15%																									
tan δ	≤ 150%																									
Leakage current (I _L)	< initial limit																									
Self inductance	Approx. 20 nH																									
Reference standards	CECC 30.300 IEC 60384-4 LONG LIFE GRADE																									

K07 TYPE STANDARD RATINGS

Cap μF	\varnothing x L mm	Tan δ MAX 120 Hz 20°C	ESR TYP m Ω 120 Hz 20°C	Ir a.c. A max 120 Hz 40°C	Ir a.c. A max 120 Hz 85°C	PART NUMBER stud and insert style excluded
6800	51x96	0.15	21	23.4	10.9	K07160682__M0G096
8200	51x105	0.15	18	27.5	12.8	K07160822__M0G105
10000	51x115	0.15	13	29.0	13.5	K07160103__M0G115
12000	51x130	0.15	13	34.1	15.8	K07160123__M0G130
10000	63x96	0.15	13	26.6	12.4	K07160103__M0H096
15000	63x105	0.15	13	31.3	14.6	K07160153__M0H105
15000	63x115	0.15	13	32.4	15.1	K07160153__M0H115
18000	63x130	0.15	12	38.1	17.7	K07160183__M0H130
22000	63x143	0.20	10	48.1	22.4	K07160223__M0H143
22000	76x105	0.20	10	48.1	22.4	K07160223__M0J105
22000	76x115	0.20	10	49.7	23.1	K07160223__M0J115
27000	76x130	0.20	10	54.4	25.3	K07160273__M0J130
33000	76x143	0.20	8	65.7	30.6	K07160333__M0J143
47000	76x214	0.25	7	81.5	37.6	K07160473__M0J214
47000	76x220	0.25	7	81.5	37.6	K07160473__M0J220

RATED
VOLTAGE
VDC

160V

Cap μF	\varnothing x L mm	Tan δ MAX 120 Hz 20°C	ESR TYP m Ω 120 Hz 20°C	Ir a.c. A max 120 Hz 40°C	Ir a.c. A max 120 Hz 85°C	PART NUMBER stud and insert style excluded
5600	51x96	0.15	27	23.0	10.7	K07200562__M0G096
6800	51x105	0.15	22	27.0	12.6	K07200682__M0G105
6800	63x96	0.15	22	26.4	12.3	K07200682__M0H096
8200	51x115	0.15	18	28.5	13.2	K07200822__M0G115
10000	51x130	0.15	13	33.4	15.5	K07200103__M0G130
10000	63x105	0.15	13	31.3	14.6	K07200103__M0H105
12000	63x115	0.15	13	31.9	14.8	K07200123__M0H115
14000	63x130	0.15	12	37.6	17.5	K07200143__M0H130
15000	63x143	0.15	12	40.4	18.8	K07200153__M0H143
15000	76x105	0.15	12	40.4	18.8	K07200153__M0J105
18000	76x115	0.15	12	44.5	20.7	K07200183__M0J115
22000	76x130	0.18	10	50.0	23.4	K07200223__M0J130
27000	76x143	0.18	9	64.6	30.0	K07200273__M0J143
33000	76x214	0.22	8	75.7	35.2	K07200333__M0J214
33000	76x220	0.22	8	75.7	35.2	K07200333__M0J220

RATED
VOLTAGE
VDC

200V

K07 TYPE STANDARD RATINGS

Cap μF	\varnothing x L mm	Tan δ MAX 120 Hz 20°C	ESR TYP m Ω 120 Hz 20°C	Ir a.c. A max 120 Hz 40°C	Ir a.c. A max 120 Hz 85°C	PART NUMBER stud and insert style excluded
3900	51x96	0.15	32	22.0	10.2	K07250392__M0G096
4700	51x105	0.15	25	25.7	11.9	K07250472__M0G105
5600	51x115	0.15	24	27.5	12.8	K07250562__M0G115
6800	51x130	0.15	19	32.1	14.9	K07250682__M0G130
4700	63x96	0.15	30	25.7	12.0	K07250472__M0H096
8200	63x105	0.15	22	30.9	14.4	K07250822__M0H105
10000	63x115	0.15	20	31.6	14.7	K07250103__M0H115
12000	63x130	0.15	19	37.1	17.2	K07250123__M0H130
12000	63x143	0.15	19	45.8	21.3	K07250123__M0H143
12000	76x105	0.15	19	45.8	21.3	K07250123__M0J105
12000	76x115	0.15	19	47.4	22.0	K07250123__M0J115
15000	76x130	0.15	16	46.3	21.5	K07250153__M0J130
18000	76x143	0.20	10	47.6	22.1	K07250183__M0J143
27000	76x214	0.25	8	70.0	32.6	K07250273__M0J214
27000	76x220	0.25	8	70.0	32.6	K07250273__M0J220

RATED
VOLTAGE
VDC

250V

Cap μF	\varnothing x L mm	Tan δ MAX 120 Hz 20°C	ESR TYP m Ω 120 Hz 20°C	Ir a.c. A max 120 Hz 40°C	Ir a.c. A max 120 Hz 85°C	PART NUMBER stud and insert style excluded
2200	51x96	0.15	31	19.4	9.0	K07315222__M0G096
2700	51x105	0.15	24	22.6	10.5	K07315272__M0G105
2700	51x115	0.15	24	23.4	10.9	K07315272__M0G115
3300	51x130	0.15	20	27.3	12.7	K07315332__M0G130
2700	63x96	0.15	24	23.2	10.8	K07315272__M0H096
3900	63x105	0.15	20	28.1	13.1	K07315392__M0H105
4700	63x115	0.15	20	29.8	13.9	K07315472__M0H115
5600	63x130	0.15	17	34.7	16.1	K07315562__M0H130
6800	63x143	0.15	14	39.8	18.5	K07315682__M0H143
5600	76x105	0.15	14	39.0	18.1	K07315562__M0J105
6800	76x115	0.15	12	42.5	19.8	K07315682__M0J115
8200	76x130	0.15	10	49.2	22.9	K07315822__M0J130
10000	76x143	0.15	8	49.4	23.0	K07315103__M0J143
15000	76x214	0.20	8	67.6	31.4	K07315153__M0J214
15000	76x220	0.25	8	67.6	31.4	K07315153__M0J220

RATED
VOLTAGE
VDC

315V

PLEASE TO CONTACT OUR TECHNICAL SERVICE FOR MORE INFORMATION OR SPEC-IN ANALYSIS.

K07 TYPE STANDARD RATINGS

Cap μF	\varnothing x L mm	Tan δ MAX 120 Hz 20°C	ESR TYP m Ω 120 Hz 20°C	Ir a.c. A max 120 Hz 40°C	Ir a.c. A max 120 Hz 85°C	PART NUMBER stud and insert style excluded
1800	51x96	0.15	33	18.8	8.7	K07350182__M0G096
2200	51x105	0.15	26	21.8	10.1	K07350222__M0G105
2700	51x115	0.15	23	23.9	11.1	K07350272__M0G115
3300	51x130	0.15	19	27.9	13.0	K07350332__M0G130
3300	63x96	0.15	27	23.5	10.9	K07350332__M0H096
3900	63x105	0.15	20	27.8	12.9	K07350392__M0H105
3900	63x115	0.15	20	28.8	13.4	K07350392__M0H115
4700	63x130	0.15	17	33.6	15.6	K07350472__M0H130
5600	63x143	0.15	13	39.8	18.5	K07350562__M0H143
5600	76x105	0.15	13	39.8	18.5	K07350562__M0J105
5600	76x115	0.15	13	41.1	19.2	K07350562__M0J115
6800	76x130	0.15	12	41.1	19.2	K07350682__M0J130
8200	76x143	0.15	12	45.2	21.0	K07350822__M0J143
10000	76x143	0.15	12	46.3	21.5	K07350103__M0J143
12000	76x214	0.20	8	66.1	30.7	K07350123__M0J214
12000	76x220	0.25	8	66.1	30.7	K07350123__M0J220

RATED
VOLTAGE
VDC

350V

Cap μF	\varnothing x L mm	Tan δ MAX 120 Hz 20°C	ESR TYP m Ω 120 Hz 20°C	Ir a.c. A max 120 Hz 40°C	Ir a.c. A max 120 Hz 85°C	PART NUMBER stud and insert style excluded
2200	51x130	0.20	77	17.37	6.53	K07400222__M0G130
2200	63x96	0.20	84	17.03	6.40	K07400222__M0H096
2700	63x96	0.20	75	19.02	7.15	K07400272__M0H096
3300	63x105	0.20	59	22.75	8.40	K07400332__M0H105
3300	63x115	0.20	59	22.75	8.55	K07400332__M0H115
3900	63x130	0.20	49	26.06	9.80	K07400392__M0H130
4700	76x105	0.20	41	28.60	10.60	K07400472__M0J105
4700	76x115	0.20	41	28.60	10.75	K07400472__M0J115
5600	76x130	0.20	34	32.45	12.20	K07400562__M0J130
6800	76x143	0.20	24	38.84	14.50	K07400682__M0J143
6800	76x155	0.20	24	38.84	14.60	K07400682__M0J155
8200	90x157	0.20	22	44.74	16.82	K07400822__M0L157

RATED
VOLTAGE
VDC

400V

Cap μF	\varnothing x L mm	Tan δ MAX 120 Hz 20°C	ESR TYP m Ω 120 Hz 20°C	Ir a.c. A max 120 Hz 40°C	Ir a.c. A max 120 Hz 85°	PART NUMBER stud and insert style excluded
1800	51x130	0.20	84	16.25	6.11	K07450182__M0G130
2200	63x96	0.20	80	17.35	6.52	K07450222__M0H096
2700	63x105	0.20	62	20.74	7.60	K07450272__M0H105
2700	63x115	0.20	62	20.74	7.80	K07450272__M0H115
3300	63x130	0.20	51	24.22	9.11	K07450332__M0H130
3900	76x105	0.20	44	26.25	9.70	K07450392__M0J105
3900	76x115	0.20	44	26.25	9.87	K07450392__M0J115
4700	76x130	0.20	36	30.90	11.62	K07450472__M0J130
5600	76x143	0.20	30	35.69	13.22	K07450562__M0J143
5600	76x155	0.20	30	35.69	13.42	K07450562__M0J155
6800	90x157	0.20	25	41.36	15.55	K07450682__M0L157
8200	90x157	0.20	22	45.09	16.95	K07450822__M0L157
10000	90x196	0.20	18	54.75	20.60	K07450103__M0L196
12000	90x220	0.20	15	63.15	23.75	K07450123__M0L220

RATED
VOLTAGE
VDC

450V

LOAD LIFE K07

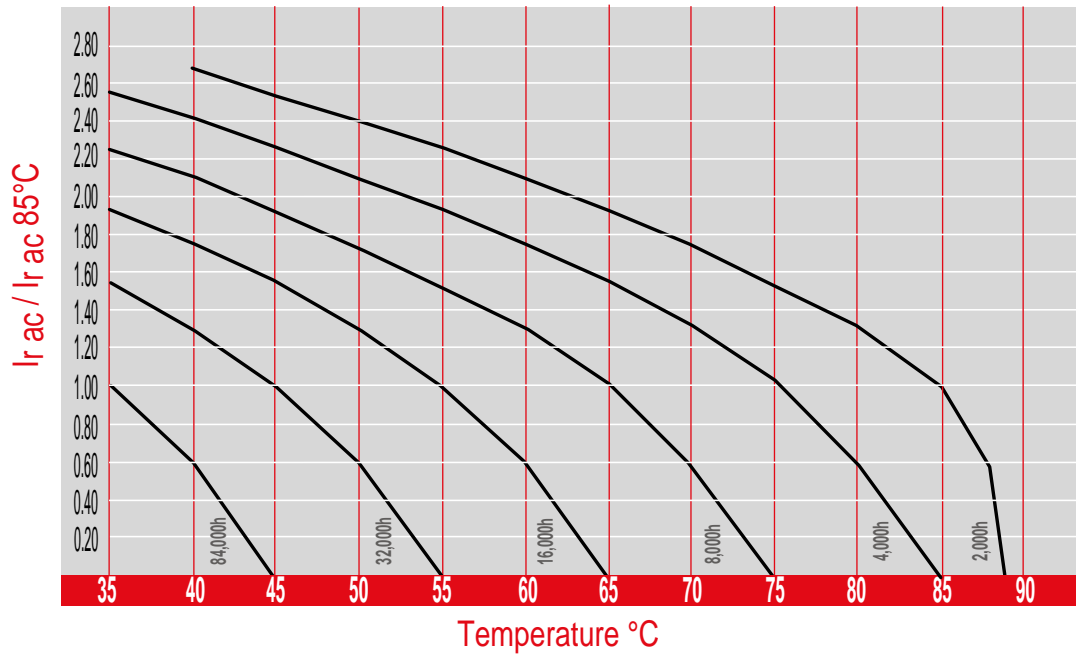

The graphs shows a typical trend of the standard capacitor load life. For a more accurate calculation of the load life for a specific capacitor, please use our calculator on the website www.kendeil.com or enquiry our technical service.